



[www.FGWilson.com](http://www.FGWilson.com)

# Modular Acoustic Enclosure

## 350 – 750 kVA Range

The innovative and functional design of the 350 – 750 kVA enclosure range ensures performance in the harshest of environments. Extremely durable and robust, the enclosures are designed to resist corrosion and handling damage with the ability to withstand rough handling common on many construction sites.

Developed through continuing research and development by our specialist engineers, all FG Wilson enclosures are fully weatherproof incorporating internally mounted exhaust silencers. Designed on modular principles, they have interchangeable components permitting on site repair.

### Robust/Highly Corrosion Resistant Construction

- Galvanised steel construction further protected by polyester powder coat paint
- Base frame extends beyond enclosure protecting against handling damage
- Reinforced lap roof joints protecting against water ingress
- Black finish stainless steel locks and hinges
- Zinc plated / stainless steel fasteners
- Corner posts manufactured from high grade composite material

### Security and Safety

- Control panel viewing window in a lockable access door
- Emergency stop push button (red) mounted on enclosure exterior
- Cooling fan and battery charging alternator fully guarded
- Fuel fill and battery can only be reached via lockable access doors
- Exhaust silencing system totally enclosed for operator safety



The CAE enclosures reduce sound levels to comply with stage II levels of the European Community Directive 2000/14/EC which became effective 3 January 2006.

The FG Wilson CAHA enclosures, also available across the entire 350 – 750 kVA range are designed for operation in high ambient environments up to 50°C, with no loss of cooling system performance.

### Excellent Service and Maintenance Access

- Large side hinged doors on both sides of enclosure providing optimal access
- Retaining bars securing door positions during servicing
- Removable ducts providing maintenance access with enclosure in place
- Radiator fill via removable, flush mounted rain cap fitted with compression seal
- Lube oil and coolant drain valves

### Transportability

- Optional tested and certified lifting arch (excluding 2806)
- Lifting, drag and jacking points on base frame

## Sound Pressure Levels (dBA) – CAE

Generating Set Model		50 Hz							60 Hz					
		LWA	15m (50ft)		7m (23ft)		1m (3ft)		15m (50ft)		7m (23ft)		1m (3ft)	
			75% Load	100% Load	75% Load	100% Load	75% Load	100% Load	75% Load	100% Load	75% Load	100% Load	75% Load	100% Load
P400-1	Prime	–	63.4	64.1	69.4	70.1	80.5	81.1	–	–	–	–	–	–
	Standby	–	63.6	64.3	69.6	70.3	80.7	81.4	–	–	–	–	–	–
P438-1	Prime	–	–	–	–	–	–	–	65.7	66.2	71.7	72.2	84.0	84.4
	Standby	–	–	–	–	–	–	–	65.9	66.4	71.9	72.4	84.1	84.5
P450-1	Prime	–	63.6	64.4	69.6	70.4	80.7	81.5	–	–	–	–	–	–
	Standby	–	63.9	64.6	69.9	70.6	81.0	81.8	–	–	–	–	–	–
P500-1	Prime	98	63.0	63.9	69.0	69.9	79.2	80.0	–	–	–	–	–	–
	Standby	98	63.3	64.2	69.3	70.2	79.4	80.3	–	–	–	–	–	–
P501-1	Prime	–	–	–	–	–	–	–	64.4	65.6	70.4	71.6	81.4	82.8
	Standby	–	–	–	–	–	–	–	64.7	66.2	70.7	72.2	81.8	83.4
P550-1	Prime	98	63.3	64.2	69.3	70.2	79.4	80.3	–	–	–	–	–	–
	Standby	98	63.6	64.6	69.6	70.6	79.7	80.7	–	–	–	–	–	–
P563-1	Prime	–	–	–	–	–	–	–	65.1	66.1	71.1	72.1	81.4	82.4
	Standby	–	–	–	–	–	–	–	65.4	66.6	71.4	72.6	81.7	82.9
P605-1	Prime	101	65.5	66.2	71.5	72.2	81.4	82.1	–	–	–	–	–	–
	Standby	101	65.7	66.4	71.7	72.4	81.6	82.2	–	–	–	–	–	–
P625-1	Prime	–	–	–	–	–	–	–	65.4	66.7	71.4	72.7	81.7	82.9
	Standby	–	–	–	–	–	–	–	65.7	67.3	71.7	73.3	82.1	83.5
P660-1	Prime	101	65.7	66.4	71.7	72.4	81.6	82.2	–	–	–	–	–	–
	Standby	101	65.9	66.6	71.9	72.6	81.8	82.4	–	–	–	–	–	–
P688-1	Prime	–	–	–	–	–	–	–	67.2	67.5	73.2	73.5	85.5	85.6
	Standby	–	–	–	–	–	–	–	67.3	67.5	73.3	73.5	85.5	85.6
P700-1	Prime	101	65.8	66.5	71.8	72.5	81.7	82.3	–	–	–	–	–	–
	Standby	101	66.1	66.7	72.1	72.7	82.0	82.4	–	–	–	–	–	–
P750-1	Prime	–	–	–	–	–	–	–	67.3	67.5	73.3	73.5	85.5	85.6
	Standby	–	–	–	–	–	–	–	67.4	67.6	73.4	73.6	85.6	85.5

These generator sets meet LWA legislation.

## CAE Sound Attenuated Enclosure

### Ambient Capability\*

Generator Set Model	Engine Model	50 Hz		60 Hz	
		°C	°F	°C	°F
P400-1	2206A-E13TAG2	54	129	–	–
P438-1	2206A-E13TAG5	–	–	57	135
P450-1	2206A-E13TAG3	49	120	–	–
P500-1	2506A-E15TAG1	46	115	–	–
P501-1	2206A-E13TAG6	–	–	51	124
P550-1	2506A-E15TAG2	41	106	–	–
P563-1	2506A-E15TAG3	–	–	48	118
P605-1	2806A-E18TAG1	50	122	–	–
P625-1	2506A-E15TAG4	–	–	44	111
P660-1	2806A-E18TAG1A	46	115	–	–
P688-1	2806A-E18TAG1A	–	–	48	118
P700-1	2806A-E18TAG2	43	109	–	–
P750-1	2806A-E18TAG3	–	–	42	108

\*Cooling system performance figures based on full load. Power output derate will apply.

## Sound Pressure Levels (dBA) – CAHA

Generating Set Model		50 Hz						60 Hz					
		15m (50ft)		7m (23ft)		1m (3ft)		15m (50ft)		7m (23ft)		1m (3ft)	
		75% Load	100% Load	75% Load	100% Load	75% Load	100% Load	75% Load	100% Load	75% Load	100% Load	75% Load	100% Load
P400-1	Prime	66.8	68.7	72.8	74.7	84.8	86.5	–	–	–	–	–	–
	Standby	67.4	69.5	73.4	75.5	85.3	87.2	–	–	–	–	–	–
P438-1	Prime	–	–	–	–	–	–	68.5	69.7	74.5	75.7	86.6	87.9
	Standby	–	–	–	–	–	–	68.9	70.2	74.9	76.2	87.0	88.5
P450-1	Prime	67.5	69.7	73.5	75.7	85.5	87.3	–	–	–	–	–	–
	Standby	68.2	70.6	74.2	76.6	86.0	88.1	–	–	–	–	–	–
P500-1	Prime	69.6	70.9	75.6	76.9	87.8	88.7	–	–	–	–	–	–
	Standby	70.0	71.3	76.0	77.3	88.1	89.0	–	–	–	–	–	–
P501-1	Prime	–	–	–	–	–	–	69.0	70.4	75.0	76.4	87.1	88.8
	Standby	–	–	–	–	–	–	69.4	71.0	75.4	77.0	87.6	89.5
P550-1	Prime	70.0	71.3	76.0	77.3	88.1	89.0	–	–	–	–	–	–
	Standby	70.4	71.8	76.4	77.8	88.4	89.3	–	–	–	–	–	–
P563-1	Prime	–	–	–	–	–	–	72.7	73.6	78.7	79.6	91.0	91.9
	Standby	–	–	–	–	–	–	73.0	74.0	79.0	80.0	91.3	92.2
P605-1	Prime	70.0	71.3	76.0	77.3	87.4	88.9	–	–	–	–	–	–
	Standby	70.4	71.7	76.4	77.7	87.8	89.5	–	–	–	–	–	–
P625-1	Prime	–	–	–	–	–	–	73.1	74.0	79.1	80.0	91.3	92.3
	Standby	–	–	–	–	–	–	73.4	74.3	79.4	80.3	91.6	92.6
P660-1	Prime	70.3	71.7	76.3	77.7	87.8	89.4	–	–	–	–	–	–
	Standby	70.8	72.1	76.8	78.1	88.3	90.1	–	–	–	–	–	–
P688-1	Prime	–	–	–	–	–	–	71.7	72.4	77.7	78.4	89.9	90.6
	Standby	–	–	–	–	–	–	71.9	72.6	77.9	78.6	90.1	90.9
P700-1	Prime	70.6	72.0	76.6	78.0	88.1	89.8	–	–	–	–	–	–
	Standby	71.1	72.4	77.1	78.4	88.6	90.5	–	–	–	–	–	–
P750-1	Prime	–	–	–	–	–	–	71.9	72.6	77.9	78.6	90.1	90.8
	Standby	–	–	–	–	–	–	72.1	72.8	78.1	78.8	90.3	91.1

## CAHA High Ambient Enclosure

### Ambient Capability\*

Generator Set Model	Engine Model	50 Hz		60 Hz	
		°C	°F	°C	°F
P400-1	2206A-E13TAG2	54	129	–	–
P438-1	2206A-E13TAG5	–	–	57	135
P450-1	2206A-E13TAG3	49	120	–	–
P500-1	2506A-E15TAG1	55	131	–	–
P501-1	2206A-E13TAG6	–	–	51	124
P550-1	2506A-E15TAG2	52	126	–	–
P563-1	2506A-E15TAG3	–	–	55	136
P605-1	2806A-E18TAG1	55	133	–	–
P625-1	2506A-E15TAG4	–	–	54	129
P660-1	2806A-E18TAG1A	54	129	–	–
P688-1	2806A-E18TAG1A	–	–	55	133
P700-1	2806A-E18TAG2	52	126	–	–
P750-1	2806A-E18TAG3	–	–	53	127

\*Designed for operation in high ambient environments up to 50°C with no loss of cooling system performance. Power output derate will apply.

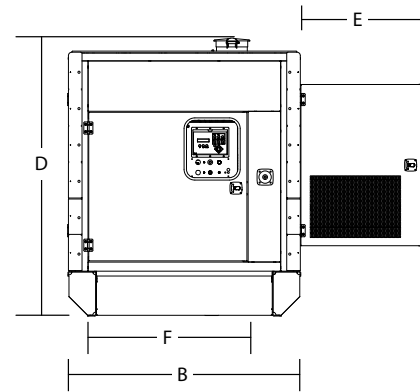
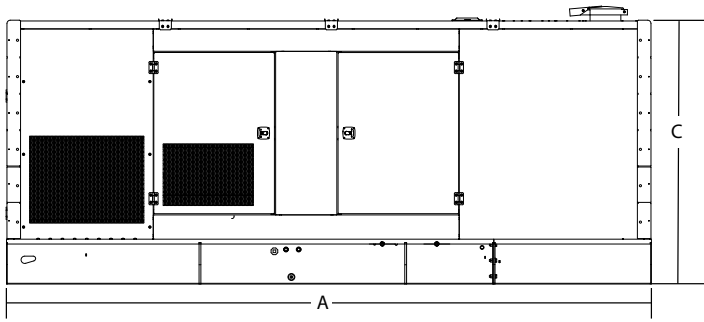

### Dimensions and Weights – CAE

Generating Set Model	A: mm (in)	B: mm (in)	C: mm (in)	D: mm (in)	E: mm (in)*	F: mm (in)	Weight: kg (lb)	Fuel Tank Fillable Capacity l (US gal)
P400-1	4930 (194.1)	1658 (65.3)	2147 (84.5)	2317 (91.2)	995 (39.2)	1236 (48.7)	4655 (10263)	887 (234)
P438-1	4930 (194.1)	1658 (65.3)	2147 (84.5)	2317 (91.2)	995 (39.2)	1236 (48.7)	4655 (10263)	887 (234)
P450-1	4930 (194.1)	1658 (65.3)	2147 (84.5)	2317 (91.2)	995 (39.2)	1236 (48.7)	4667 (10289)	887 (234)
P500-1	4930 (194.1)	1658 (65.3)	2147 (84.5)	2317 (91.2)	995 (39.2)	1236 (48.7)	5106 (11257)	887 (234)
P501-1	4930 (194.1)	1658 (65.3)	2147 (84.5)	2317 (91.2)	995 (39.2)	1236 (48.7)	4655 (10263)	887 (234)
P550-1	4930 (194.1)	1658 (65.3)	2147 (84.5)	2317 (91.2)	995 (39.2)	1236 (48.7)	5230 (11530)	887 (234)
P563-1	4930 (194.1)	1658 (65.3)	2147 (84.5)	2317 (91.2)	995 (39.2)	1236 (48.7)	5106 (11257)	887 (234)
P605-1	5320 (209.4)	1920 (75.6)	2177 (85.7)	2289 (90.1)	995 (39.2)	1236 (48.7)	5684 (12531)	1157 (306)
P625-1	4930 (194.1)	1658 (65.3)	2147 (84.5)	2317 (91.2)	995 (39.2)	1236 (48.7)	5230 (11530)	887 (234)
P660-1	5320 (209.4)	1920 (75.6)	2177 (85.7)	2289 (90.1)	995 (39.2)	1236 (48.7)	5684 (12531)	1157 (306)
P688-1	5320 (209.4)	1920 (75.6)	2177 (85.7)	2289 (90.1)	995 (39.2)	1236 (48.7)	5684 (12531)	1157 (306)
P700-1	5320 (209.4)	1920 (75.6)	2177 (85.7)	2289 (90.1)	995 (39.2)	1236 (48.7)	5724 (12619)	1157 (306)
P750-1	5320 (209.4)	1920 (75.6)	2177 (85.7)	2289 (90.1)	995 (39.2)	1236 (48.7)	5684 (12531)	1157 (306)

Weight with lube oil and coolant, no fuel.

\*Clearance required on both sides.

### Dimensions and Weights – CAHA

Generating Set Model	A: mm (in)	B: mm (in)	C: mm (in)	D: mm (in)	E: mm (in)*	F: mm (in)	Weight: kg (lb)	Fuel Tank Fillable Capacity l (US gal)
P400-1	4930 (194.1)	1658 (65.3)	2147 (84.5)	2317 (91.2)	995 (39.2)	1236 (48.7)	4655 (10263)	887 (234)
P438-1	4930 (194.1)	1658 (65.3)	2147 (84.5)	2317 (91.2)	995 (39.2)	1236 (48.7)	4655 (10263)	887 (234)
P450-1	4930 (194.1)	1658 (65.3)	2147 (84.5)	2317 (91.2)	995 (39.2)	1236 (48.7)	4667 (10289)	887 (234)
P500-1	4930 (194.1)	1658 (65.3)	2147 (84.5)	2317 (91.2)	995 (39.2)	1236 (48.7)	5106 (11257)	887 (234)
P501-1	4930 (194.1)	1658 (65.3)	2147 (84.5)	2317 (91.2)	995 (39.2)	1236 (48.7)	4655 (10263)	887 (234)
P550-1	4930 (194.1)	1658 (65.3)	2147 (84.5)	2317 (91.2)	995 (39.2)	1236 (48.7)	5230 (11530)	887 (234)
P563-1	4930 (194.1)	1658 (65.3)	2147 (84.5)	2317 (91.2)	995 (39.2)	1236 (48.7)	5106 (11257)	887 (234)
P605-1	5320 (209.4)	1920 (75.6)	2177 (85.7)	2289 (90.1)	995 (39.2)	1236 (48.7)	5684 (12531)	1157 (306)
P625-1	4930 (194.1)	1658 (65.3)	2147 (84.5)	2317 (91.2)	995 (39.2)	1236 (48.7)	5230 (11530)	887 (234)
P660-1	5320 (209.4)	1920 (75.6)	2177 (85.7)	2289 (90.1)	995 (39.2)	1236 (48.7)	5684 (12531)	1157 (306)
P688-1	5320 (209.4)	1920 (75.6)	2177 (85.7)	2289 (90.1)	995 (39.2)	1236 (48.7)	5684 (12531)	1157 (306)
P700-1	5320 (209.4)	1920 (75.6)	2177 (85.7)	2289 (90.1)	995 (39.2)	1236 (48.7)	5724 (12619)	1157 (306)
P750-1	5320 (209.4)	1920 (75.6)	2177 (85.7)	2289 (90.1)	995 (39.2)	1236 (48.7)	5684 (12531)	1157 (306)

Weight with lube oil and coolant, no fuel.

\*Clearance required on both sides.

### FG Wilson manufactures product in the following locations:

Northern Ireland • Brazil • China • India • USA

With headquarters in Northern Ireland, FG Wilson operates through a Global Dealer Network.

To contact your local Sales Office please visit the FG Wilson website at [www.FGWilson.com](http://www.FGWilson.com).

FG Wilson is a trading name of Caterpillar (NI) Limited.