



www.FGWilson.com



Image for illustration purposes only.

P200-2

Output Ratings

Generating Set Model	Prime	Standby
380-415V, 50Hz	180.0 kVA / 144.0 kW	200.0 kVA / 160.0 kW
480V, 60 Hz	196.3 kVA / 157.0 kW	217.5 kVA / 174.0 kW

Ratings at 0.8 power factor.

Prime Rating

These ratings are applicable for supplying continuous electrical power (at variable load) in lieu of commercially purchased power. There is no limitation to the annual hours of operation and this model can supply 10% overload power for 1 hour in 12 hours.

Standby Rating

These ratings are applicable for supplying continuous electrical power (at variable load) in the event of a utility power failure. No overload is permitted on these ratings. The alternator on this model is peak continuous rated (as defined in ISO 8528-3).

Standard Reference Conditions

Note: Standard reference conditions 25°C (77°F) Air Inlet Temp, 100m (328 ft) A.S.L. 30% relative humidity. Fuel consumption data at full load with diesel fuel with specific gravity of 0.85 and conforming to BS2869: 1998, Class A2.

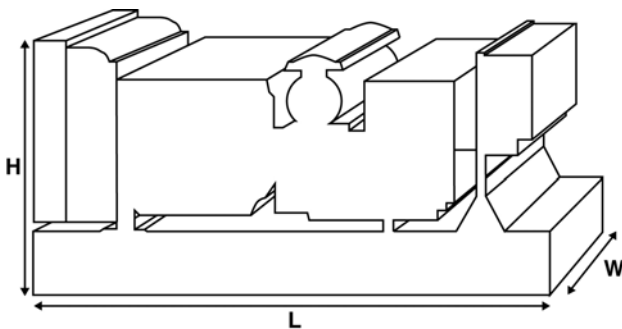

Ratings and Performance Data

Engine Make & Model:	Perkins 1106C-E66TAG4	
Alternator manufactured for FG Wilson by:	Leroy Somer	
Alternator Model:	LL5014D	
Control Panel:	PowerWizard 1.1	
Base Frame:	Heavy Duty Fabricated Steel	
Circuit Breaker Type:	3 Pole MCCB	
Frequency:	50 Hz	60 Hz
Engine Speed: RPM	1500	1800
Fuel Tank Capacity: litres (US gal)	418 (110.4)	
Fuel Consumption: l/hr (US gal/hr)		
(100% Load)	- Prime	44.5 (11.8)
	- Standby	48.6 (12.8)
		40.0 (10.6)

Available Options

FG Wilson offer a range of optional features to tailor our generating sets to meet your power needs. Options include:

- Upgrade to CE Certification
- A wide range of Sound Attenuated Enclosures
- A variety of generating set control and synchronising panels
- Additional alarms and shutdowns
- A selection of exhaust silencer noise levels

For further information on all of the standard and optional features accompanying this product please contact your local Dealer or visit: www.FGWilson.com

Dimensions and Weights

Length (L) mm (in)	Width (W) mm (in)	Height (H) mm (in)	Dry kg (lb)	Wet kg (lb)
2500 (98.4)	1320 (52.0)	1626 (64.0)	1691 (3728)	1718 (3788)

Dry = With Lube Oil

Wet = With Lube Oil and Coolant

Ratings in accordance with ISO 8528, ISO 3046, IEC 60034, BS5000 and NEMA MG-1/22. Generating set pictured may include optional accessories.

Engine Technical Data	
No. of Cylinders / Alignment:	6 / In Line
Cycle:	4 Stroke
Bore / Stroke: mm (in)	105.0 (4.1)/127.0 (5.0)
Induction:	Turbocharged Air To Air Charge Cooled
Cooling Method:	Water
Governing Type:	Electronic
Governing Class:	ISO 8528 G2
Compression Ratio:	16.2:1
Displacement: l (cu. in)	6.6 (402.8)
Moment of Inertia: kg m ² (lb/in ²)	1.61 (5502)
Engine Electrical System:	
- Voltage / Ground	12/Negative
- Battery Charger Amps	100
Weight: kg (lb)	
- Dry	788 (1737)
- Wet	822 (1812)

Performance	50 Hz	60 Hz
Engine Speed: rpm	1500	1800
Gross Engine Power: kW (hp)		
- Prime	163.7 (220.0)	185.3 (248.0)
- Standby	180.5 (242.0)	204.3 (274.0)
BMEP: kPa (psi)		
- Prime	1985.0 (287.9)	1872.0 (271.5)
- Standby	2188.0 (317.4)	2064.0 (299.4)

Fuel System				
Fuel Filter Type:	Replaceable Element			
Recommended Fuel:	Class A2 Diesel			
Fuel Consumption: l/hr (US gal/hr)				
	110%	100%	75%	50%
Prime	Load	Load	Load	Load
50 Hz	43.9 (11.6)	40.0 (10.6)	30.7 (8.1)	20.8 (5.5)
60 Hz	48.6 (12.8)	44.5 (11.8)	35.5 (9.4)	27.3 (7.2)
		100%	75%	50%
Standby		Load	Load	Load
50 Hz		43.9 (11.6)	33.9 (9.0)	23.0 (6.1)
60 Hz		48.6 (12.8)	38.3 (10.1)	29.0 (7.7)

(Based on diesel fuel with a specific gravity of 0.85 and conforming to BS2869, Class A2)

Air Systems	50 Hz	60 Hz
Air Filter Type:	Paper Element	
Combustion Air Flow: m ³ /min (cfm)		
- Prime	11.3 (399)	13.3 (470)
- Standby	11.7 (413)	13.4 (473)
Max. Combustion Air Intake Restriction: kPa (in H ₂ O)	8.0 (32.1)	8.0 (32.1)

Cooling System	50 Hz	60 Hz
Cooling System Capacity: l (US gal)	27.0 (7.1)	27.0 (7.1)
Water Pump Type: Centrifugal		
Heat Rejected to Water & Lube Oil:		
kW (Btu/min)		
- Prime	72.8 (4140)	82.2 (4675)
- Standby	79.8 (4538)	89.5 (5090)
Heat Radiation to Room: Heat radiated from engine and alternator		
kW (Btu/min)		
- Prime	25.4 (1444)	28.0 (1592)
- Standby	28.8 (1638)	31.4 (1786)
Radiator Fan Load: kW (hp)	6.3 (8.5)	14.7 (19.7)
Radiator Cooling Airflow: m ³ /min (cfm)	309.0 (10912)	385.0 (13596)
External Restriction to Cooling Airflow: Pa (in H ₂ O)	125 (0.5)	125 (0.5)

Designed to operate in ambient conditions up to 50°C (122°F). Contact your local FG Wilson Dealer for power ratings at specific site conditions.

Lubrication System	
Oil Filter Type:	Spin-On, Full Flow
Total Oil Capacity: l (US gal)	16.5 (4.4)
Oil Pan: l (US gal)	15.5 (4.1)
Oil Type:	API CH4 / CI4 15W-40
Oil Cooling Method:	Water

Exhaust System	50 Hz	60 Hz
Silencer Type:	Industrial	
Silencer Model & Quantity:	SD100 (1)	
Pressure Drop Across Silencer System: kPa (in Hg)	2.14 (0.632)	0.54 (0.159)
Silencer Noise Reduction Level: dB	14	12
Maximum Allowable Back Pressure: kPa (in Hg)	10.0 (3.0)	15.0 (4.4)
Exhaust Gas Flow: m ³ /min (cfm)		
- Prime	29.4 (1038)	33.4 (1180)
- Standby	31.0 (1095)	34.8 (1229)
Exhaust Gas Temperature: °C (°F)		
- Prime	480 (896)	485 (905)
- Standby	499 (930)	509 (948)

Alternator Physical Data	
Manufactured for FG Wilson by:	Leroy Somer
Model:	LL5014D
No. of Bearings:	1
Insulation Class:	H
Winding Pitch Code:	2/3 - 6
Wires:	12
Ingress Protection Rating:	IP23
Excitation System:	SHUNT
AVR Model:	R250

Alternator Operating Data		
Overspeed: rpm	2250	
Voltage Regulation: (Steady state)	+/- 0.5%	
Wave Form NEMA = TIF:	50	
Wave Form IEC = THF:	2.0%	
Total Harmonic content LL/LN:	4.0%	
Radio Interference:	Suppression is in line with European Standard EN61000-6	
Radiant Heat: kW (Btu/min)		
	- 50 Hz	15.1 (859)
	- 60 Hz	15.7 (893)

Alternator Performance Data:	50 Hz				60 Hz				
	415/240V	400/230V 230/115V 200/115V	380/220V 220/110V	220/127V	480/277V 240/139V	380/220V 220/110V	240/120V 208/120V	230/115V	440/254V 220/127V
Motor Starting Capability* kVA	352	331	302	389	387	257	302	282	333
Short Circuit Capacity** %	300	300	300	300	300	300	300	300	300
Reactances: Per Unit									
Xd	2.890	3.110	3.440	2.280	2.820	4.460	3.750	4.050	3.360
X'd	0.146	0.158	0.175	0.116	0.144	0.230	0.190	0.210	0.171
X''d	0.088	0.095	0.105	0.069	0.086	0.136	0.114	0.123	0.102

Reactances shown are applicable to prime ratings.
 *Based on 30% voltage dip at 0.6 power factor and SHUNT excitation.
 **With optional permanent magnet generator.

Voltage Technical Data 50 Hz				
Voltage	Prime:		Standby:	
	kVA	kW	kVA	kW
415/240V	180.0	144.0	198.0	158.4
400/230V	180.0	144.0	200.0	160.0
380/220V	180.0	144.0	200.0	160.0
230/115V	180.0	144.0	200.0	160.0
220/127V	160.0	128.0	176.0	140.8
220/110V	180.0	144.0	200.0	160.0
200/115V	180.0	144.0	200.0	160.0

Voltage Technical Data 60 Hz				
Voltage	Prime:		Standby:	
	kVA	kW	kVA	kW
480/277V	196.3	157.0	217.5	174.0
220/127V	196.3	157.0	217.5	174.0
380/220V	194.6	155.7	215.1	172.1
240/120V	196.0	156.8	217.0	173.6
230/115V	195.6	156.5	216.4	173.1
440/254V	196.3	157.0	217.5	174.0
220/110V	194.6	155.7	215.1	172.1
208/120V	196.0	156.8	217.0	173.6
240/139V	196.3	157.0	217.5	174.0

Documentation

A full set of operation and maintenance manuals and circuit wiring diagrams.

Generating Set Standards

The equipment meets the following standards: BS5000, ISO 8528, ISO 3046, IEC 60034, NEMA MG-1.22.

FG Wilson is a fully accredited ISO 9001 company.

EU Stage II Emissions Compliant.

Warranty

All prime equipment carries a one year manufacturer's warranty. Standby equipment, limited to 500 running hours per year, has a two year manufacturer's warranty. For details on warranty cover please contact your local Dealer, or visit our website: FGWilson.com.

Dealer contact details:

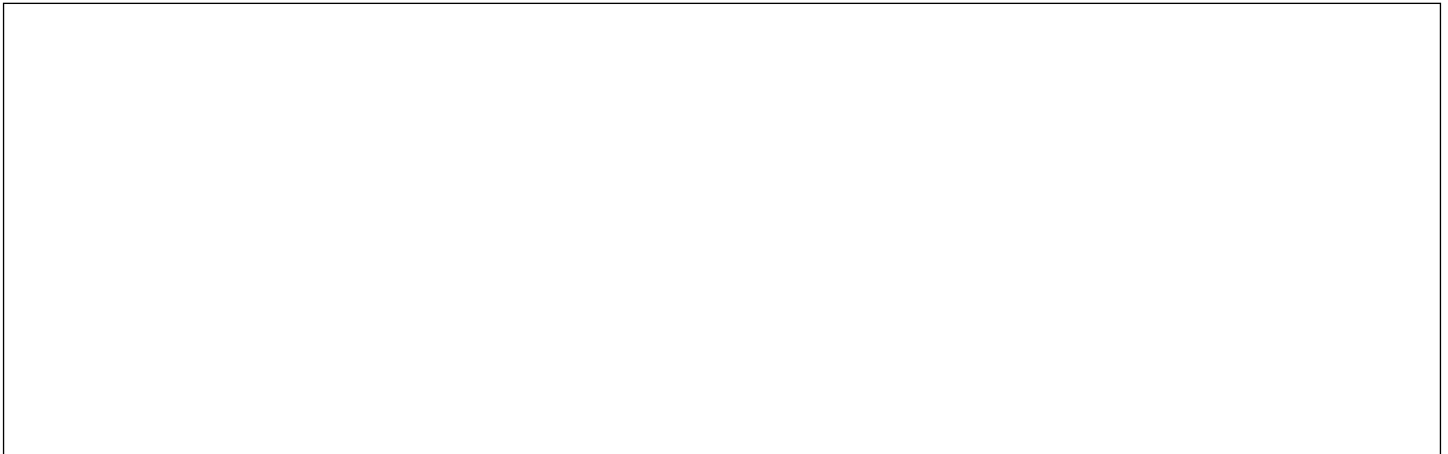

FG Wilson manufactures product in the following locations:

Northern Ireland • Brazil • China • India • USA

With headquarters in Northern Ireland, FG Wilson operates through a Global Dealer Network.

To contact your local Sales Office please visit the FG Wilson website at www.FGWilson.com.

FG Wilson is a trading name of Caterpillar (NI) Limited

In line with our policy of continuous product development, we reserve the right to change specification without notice.